

## ENEKA UAB

Vandžiogalos str. 94, LT-47467 Kaunas, Lithuania

Tel. +370 37 377441, +370 37 377880

Fax +370 37 377907

E-mail: [info@eneka.lt](mailto:info@eneka.lt)

[www.eneka.lt](http://www.eneka.lt)



# MAINS SEPARATOR ALARM



## INSTALLATION & OPERATIONS MANUAL

# Mains Powered Separator Alarm

Installation, Operation and Maintenance

## Contents

IMPORTANT .....	3
General Description .....	4
General Operation.....	4
Changing Factory Settings .....	4
Alarm Type.....	4
Check Interval.....	5
Testing the Probe Sensors .....	5
Installation .....	5
Control Unit .....	5
Probes (High Oil & High Liquid Level Probes) .....	5
Silt Probe.....	6
Cable Distribution Box .....	6
Connection to Control Unit .....	6
Using a Junction Box.....	6
Maintenance and Repair .....	6
Technical Information.....	7
Electrical .....	7
Apparatus Supply and I/O Parameters .....	7
Probe Cables.....	7
Mechanical .....	7
Probe Enable Jumper Links .....	8
Probe Cable Terminals.....	9
Flashing Beacon Wiring.....	9
Accessories .....	10

# Separator Alarm

## Installation, Operation & Maintenance

Name and Address	<b>ENEKA UAB</b> Vandžiogalos str. 94, LT-47467 Kaunas, Lithuania Tel. +370 37 377441, +370 37 377880 Fax +370 37 377907 E-mail: <a href="mailto:info@eneka.lt">info@eneka.lt</a> <a href="http://www.eneka.lt">www.eneka.lt</a>
European Directive	94/9/EC
Equipment Name and Type	Separator Monitor Type 14300
Certificate Number	Baseefa 08ATEX0110/2 IECEX BAS 11.0095
Specific Marking of Explosion Protection	[Ex ia] IIC (-20°C ≤ Ta ≤ +50°C)
ATEX Directive Marking	Ex II (1) G
Notified Body	Baseefa 1180 Buxton UK
CE Mark with Notified Body Number	CE <sub>1180</sub>
Harmonised Standards Used	EN 60079-0:2006 EN 60079-11:2007
Specific Marking of Explosion Protection	[Ex ia] IIC (-20°C ≤ Ta ≤ +50°C)
On behalf of the above named company, I declare that, on the date the equipment accompanied by this declaration is placed on the market, the equipment conforms with all technical and regulatory requirements of the above listed directives.	

### IMPORTANT

Note: In all cases good, standard electrical practice should be followed, and the installation must conform to the appropriate local code of practice – e.g. EN 60079-25. In essence, the installation must be such that the intrinsic safety is not compromised by: - exposure to risk of mechanical damage, unauthorised modification or interference, exposure to moisture, dust and foreign bodies, excessive heat, invasion of intrinsically safe circuit by other electrical equipment or circuitry. (See Note in installation section)

# Mains Powered Separator Alarm

Installation, Operation and Maintenance

## General Description

The standard system is supplied complete with an intrinsically safe control unit together with a high oil probe. The control unit is capable of monitoring up to 3 probe units, displaying their current status via a 2 x 16 display. The output relay enables this status to be signalled to a remote location or activate a beacon if required.

## General Operation

The Control Unit monitors the condition of the connected probe units by checking their condition every 30 minutes<sup>1</sup>, their current status is displayed on the display located on the front of the unit. If an alarm condition is detected, a warning message is displayed followed by notification of the alarm condition detected, e.g. \*HAZARD ALERT\* High Oil Alarm, the output relay becomes de-energised and the internal buzzer is audible.

The unit then gives the option, via the display, to accept/acknowledge the alarm. On doing so, the output relay energises, the buzzer is muted and the display instructs the user to take the appropriate action, e.g. empty the separator. After the separator has been emptied and refilled with water, the control unit re-scans the probe sensors attached and presuming no alarm condition is detected, 'All Correct' will be displayed. If the push button is pressed before the separator has been emptied, or it has been emptied but not refilled with water, then the control simply scans the probe sensor(s) and reverts to the alarm condition. Please note the output relay is de-energised on detection of any alarm condition or mains failure.

## Changing Factory Settings

### Alarm Type

The factory setting is STD (standard), this is where the output relay de-energises upon fault detection and energises upon acceptance of the fault.

Alarm Type EXT (Extended) allows the relay to remain de-energised until all alarm conditions become normal.

To enter the "Set Up" mode, firstly remove power from the unit. Whilst holding down the Push Switch, power up the unit keeping the Push Switch depressed, after about 10 seconds the screen will display "Set Up", at this point release the Push Switch.

The display will now show Alarm Type: with a flashing cursor over STD, to change this function to EXT, press the Push Switch once.

---

<sup>1</sup> The unit is factory set to 30 minutes, but in extreme conditions, this can be manually changed from 2 to 60 minutes at one minute intervals. (see Changing Factory Settings)

# Mains Powered Separator Alarm

Installation, Operation and Maintenance

## Check Interval

Whilst still in the Set Up mode, power down and then power up the unit, the flashing cursor will now be next to Check Intvl: - by pressing the Push Switch, the time can be altered in increments of 1 minute between 2 and 60.

To exit the Set Up mode at any time, hold the Push Switch whilst powering down and then power up again before releasing the Switch, this will return to the main screen sequence.

## Testing the Probe Sensors

The probe interrogation function can be activated at any time by simply pressing the push switch.

## Installation

This product has been designed and certified as being intrinsically safe. It is of paramount importance, that the unit should not be modified in any way and the installation be carried out by an approved installer, in accordance with the Environment Agency guidelines (PPG3). Any deviation from this could invalidate the certification warranty and render the unit unsafe for its intended use.

Upon powering up the unit for the first time, the LCD will display the following message:

**HAZARDOUS AREA EQUIPMENT**

**ACTIVATION CODE REQUIRED**

The unit will not be able to function without the code which can be obtained by calling Eneka on tel. +370 37 377441 / email info@eneka.lt.

## Control Unit

Refer to Table 4 on page 7 for required cable specifications.

The control unit must be positioned in a non-hazardous area. For all wiring details, refer to Figure 1, Table 5 and Table 6 on page 9.

## Probes (High Oil & High Liquid Level Probes)

The high oil probe is to be installed in the separator tank such that the float housing is below the static liquid level. If a high liquid probe is required, this needs to be installed such that the float switch housing is located above the static liquid level. Both probe cables can be secured inside the neck of the separator using a probe cord guide.

Please note the distance above or below the static liquid level will be determined by the type, style and/or size of separator, this information can be obtained from the separator manufacturer. However, as a general rule of thumb, the high liquid level probe should be placed 300mm above the static liquid level and the high oil probe 150mm below.

# Mains Powered Separator Alarm

## Installation, Operation and Maintenance

Due to the varying neck lengths (turrets) that occur within each separator, each normal probe unit is fitted with 5 metres of cable.

### Silt Probe

The probe is suspended in the separator to a pre determined depth and the cable can be secured to the neck of the separator using a probe cord guide.

### Cable Distribution Box

It is advisable to connect the probe cables to a cable distribution box which should be fixed near to the top of the separator neck. The probe cable can then be terminated with a waterproof plug (provided with the distribution box). The plug is then connected to the bulkhead socket (provided with the distribution box). A cable must then be laid to connect the distribution box and the control unit. The type of connection cable required will be dependent on the environment it is used in, the route taken and maximum allowable cable capacitance and inductance (see cable parameters in Table 4 on page 7).

After making the connections in the distribution box, it is advisable to spray the terminals with a conformal coating lacquer to prevent moisture ingress before finally sealing them with waterproof putty.

### Connection to Control Unit

The Probe cable should be fed through the appropriate gland in the bottom right hand side of the control unit and connected to the terminals as instructed. The mains cable, and if used, any beacon or sounder cable, must be fed through the appropriate gland on the bottom left hand side of the control unit and connected to the terminals as instructed.

**IMPORTANT NOTE:** Under NO circumstances must the control unit casing be drilled to allow cable entry in any area(s) other than those already provided, as this would infringe the certification and therefore safety of the product.

### Using a Junction Box

An intrinsically safe junction box should be used where incoming cable sizes have to be reduced to gain entry through the cable glands in the base of the control unit.

**IMPORTANT NOTE:** Under NO circumstances must mains and probe cable joints be made within the same junction box other than a junction box that is approved Intrinsically safe for such purpose, as this would infringe the certification and therefore safety of the installed system.

### Maintenance and Repair

Due to the harsh environments which the probes can be subjected to, it is advised that they are inspected and cleaned with a damp cloth at regular intervals. The control unit does not contain user serviceable parts. For all repairs, contact Eneka on tel. +370 37 377441 or e-mail ek@eneka.lt.

# Mains Powered Separator Alarm

Installation, Operation and Maintenance

## Technical Information

### Electrical

Supply Voltage		230V $\pm$ 10% 50Hz
Input Current	Normal condition	41mA
	Alarm condition	40mA
Fusing	Primary (FS2)	T 315mA H 250V
	Secondary (FS3)	50mA (Baseefa approved)
Max probe cable length		200m (less if values in <a href="#">Table 4</a> would be exceeded)
Relay Output		Volt-free SPCO contact
Panel rating		3A
Panel dimensions		IP65 180mm x 180mm x 60mm

Table 1 – Electrical Specifications

### Apparatus Supply and I/O Parameters

$U_m$	253Vrms
-------	---------

Table 2 – Mains Supply and Relay Contact Terminals (TB2 & TB3)

$U_o$	12.6V
$I_o$	87mA
$P_o$	273mW
$C_i$	0
$L_i$	0

Table 3 – Hazardous Area Terminals (TB1)

Group	Capacitance ( $\mu$ F)	Inductance (mH)	OR	L/R Ratio ( $\mu$ H/ $\Omega$ )
IIC	1.15	4.6		74
IIB	7.4	18.7		298
IIA	27	37.5		596

Table 4 – TB1 Load Parameters

### Probe Cables

The total capacitance and inductance of the cable used between the control unit and the probe must not exceed that shown in [Table 4](#).

### Mechanical

Protection and/or screening of the cable should also be taken into account. The maximum length of cable between probe and control unit must not exceed 200 metres or less if the values in [Table 4](#) would be exceeded.

# Mains Powered Separator Alarm

Installation, Operation and Maintenance

## Probe Enable Jumper Links

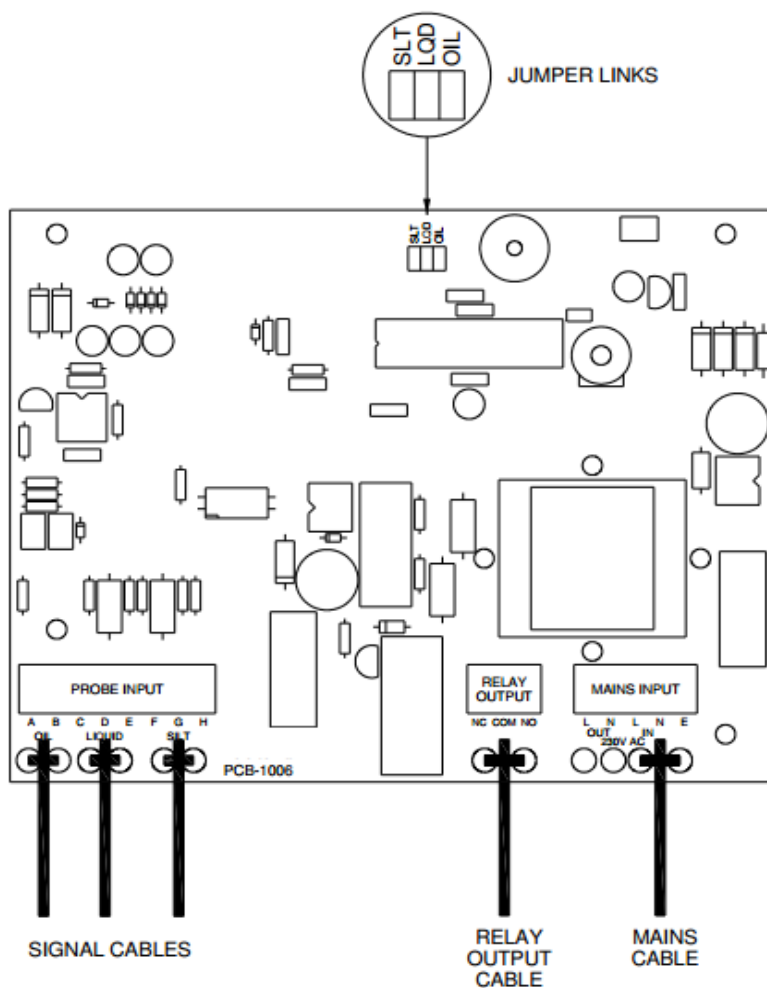

Figure 1 - Probe enable jumper links



# Mains Powered Separator Alarm

Installation, Operation and Maintenance

To operate a probe, REMOVE appropriate jumper link

Probe Type	Remove Link
High Oil	OIL
High Liquid	LQD
Silt	SLT

Table 5 – Probe enable jumper links

## Probe Cable Terminals

Probe Type	A	B	C	D	E	F	G	H
High Oil	RED	BLUE						
High Liquid			-	RED	BLUE			
Liquid (Optical)			BROWN	GREEN/YELLOW	BLUE			
Silt						BROWN	GREEN/YELLOW	BLUE

Table 6 - Probes cable wiring connection details

## Flashing Beacon Wiring

The relay output terminals, TB2, may be used to operate a 230V flashing beacon when an alarm occurs. The beacon should be wired according to [Table 7](#) and [Table 8](#). Any commoning of live and neutral connections must be done externally to the unit's enclosure.

TB2 Terminal	Connect To
NO	No Connection
COM	TB3 Mains live
NC	Beacon Live Terminal

Table 7 – wiring from relay output to beacon

TB3 Mains Terminal	Connect To
L out	TB2 COM Terminal
N out	Beacon Neutral Terminal
E	Mains earth

Table 8 – wiring to beacon from relay output

# Mains Powered Separator Alarm

Installation, Operation and Maintenance

## Accessories

	Part No.
High Oil Probe (conductivity) -----	14200
High Level Probe -----	14210
Silt Probe -----	14220
230 VAC Flashing Amber Beacon (Includes mounting bracket and glands) -----	14012
230 VAC Flashing Amber Beacon & Siren (Includes mounting bracket and glands) -----	14100
Probe Cord Guide -----	14103
Signal Distribution Box -----	14039
Intrinsically Safe Junction Box (Power & Probe) -----	14006